

FIG. 1

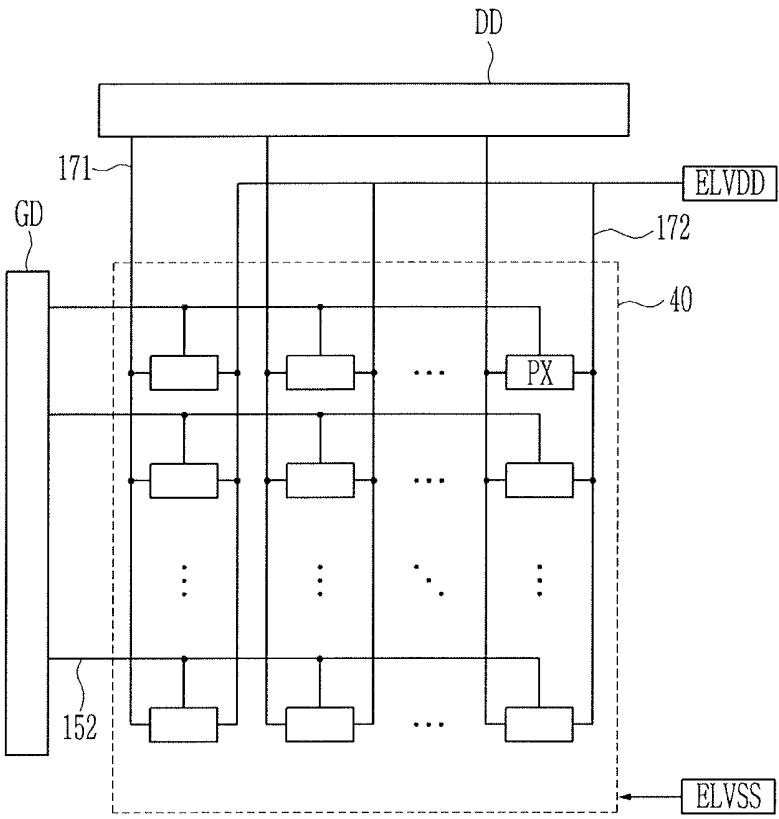

FIG. 2

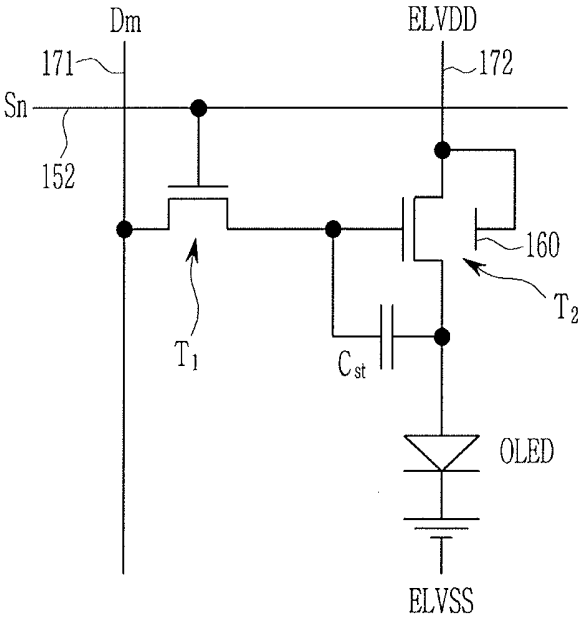

FIG. 3

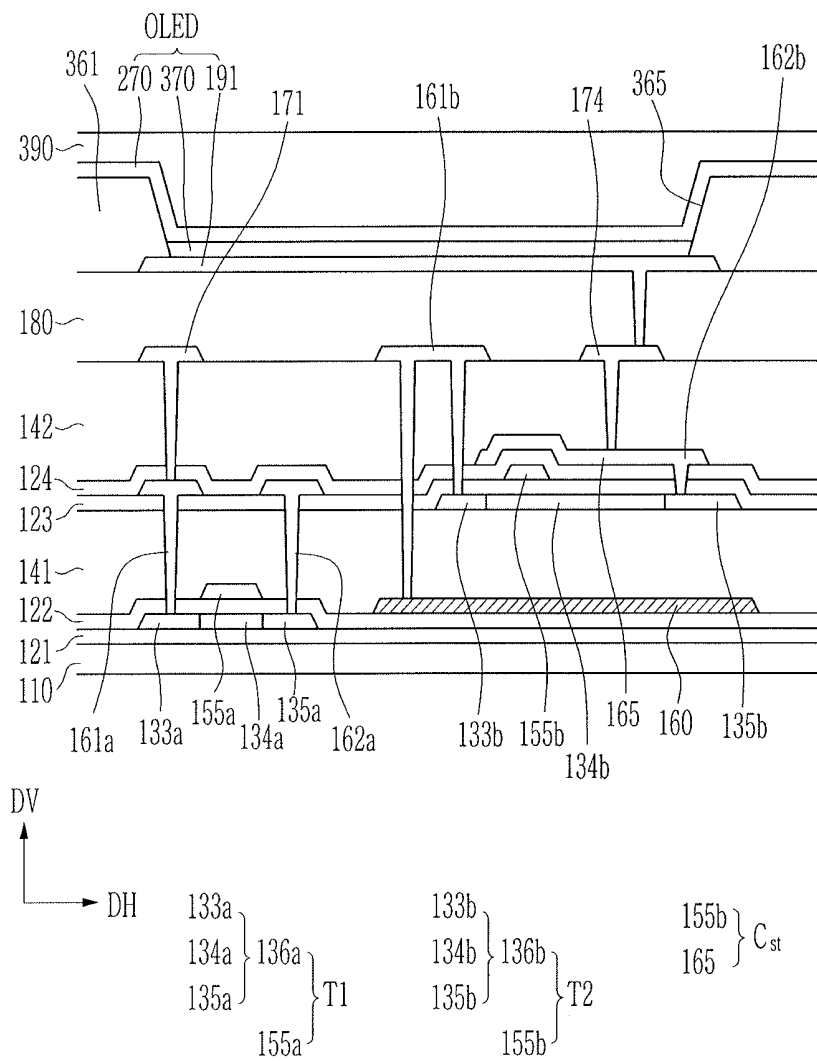

FIG. 4

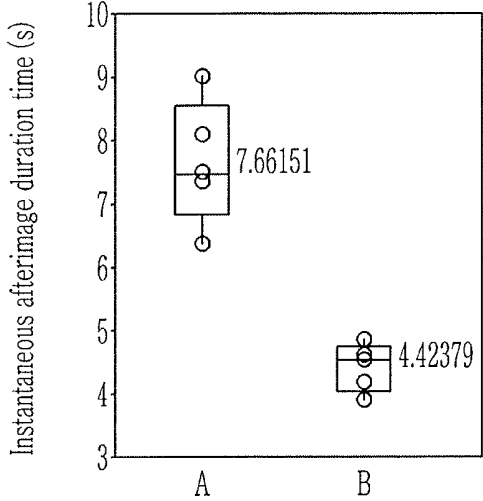

FIG. 5

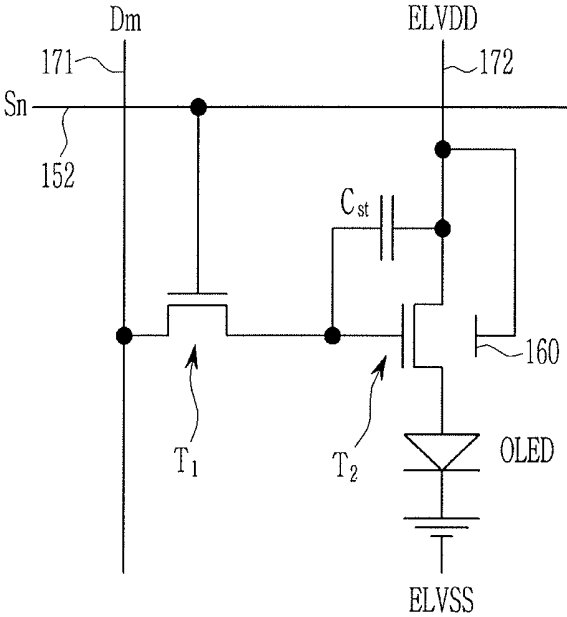

FIG. 6

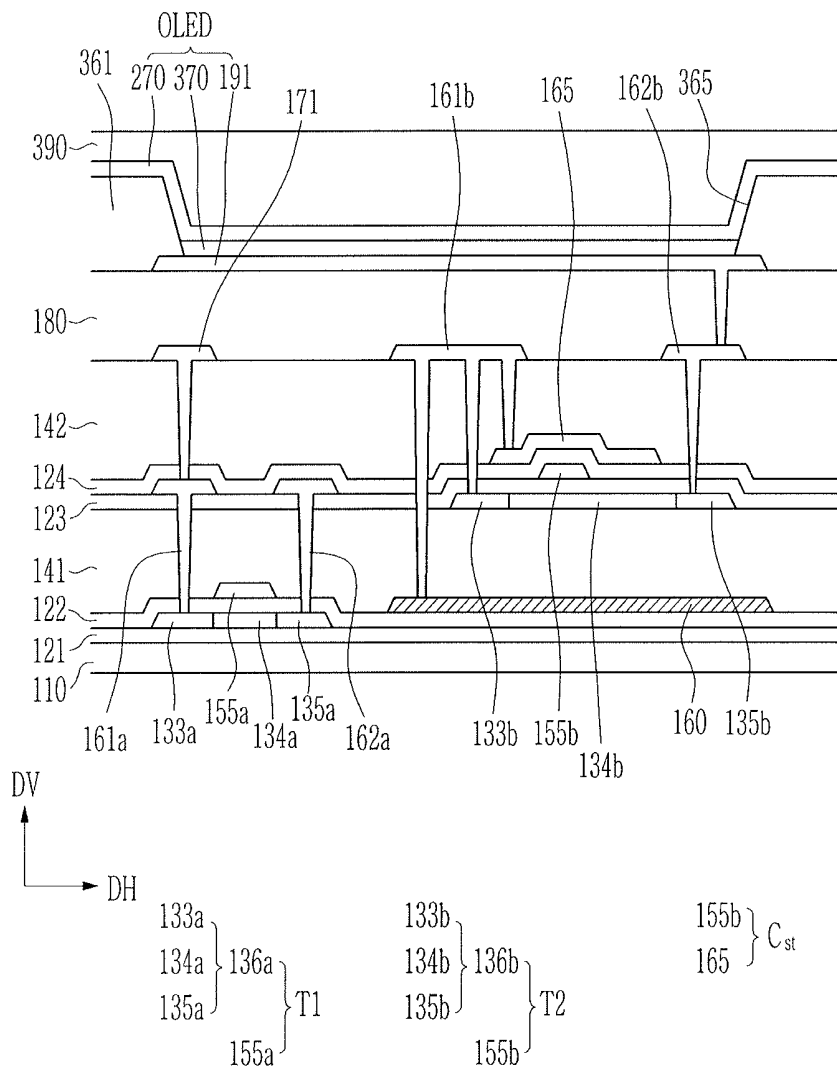
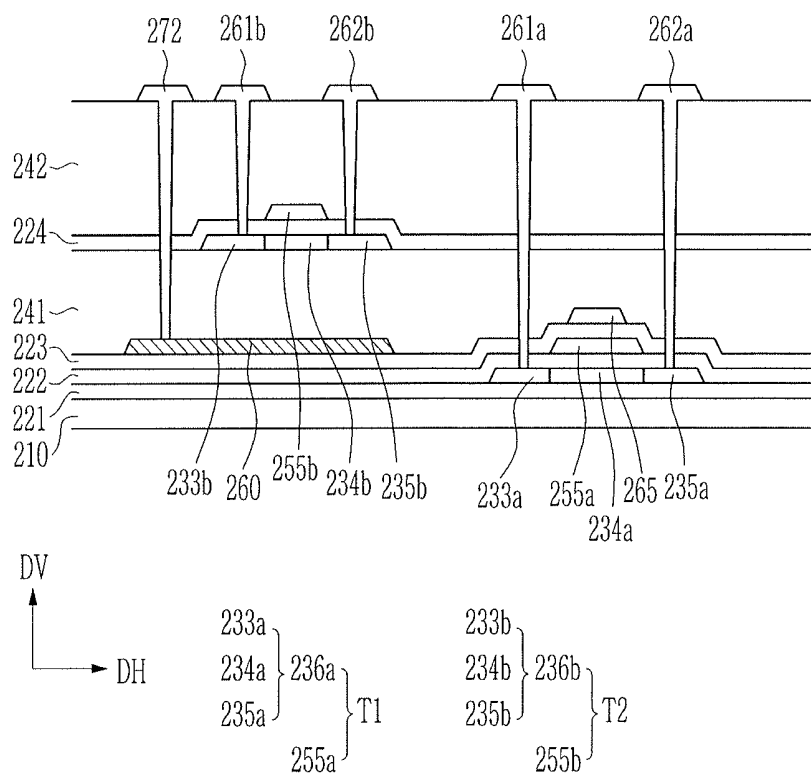

FIG. 7



ORGANIC LIGHT EMITTING DIODE DISPLAY

CROSS-REFERENCE TO RELATED APPLICATION

[0001] Korean Patent Application No. 10-2018-0118769, filed on Oct. 5, 2018, in the Korean Intellectual Property Office, and entitled: "Organic Light Emitting Diode Display," is incorporated by reference herein in its entirety.

BACKGROUND

1. Field

[0002] The present disclosure relates to an organic light emitting diode display.

2. Description of the Related Art

[0003] An organic light emitting element of an organic light emitting diode display includes two electrodes and an organic light emitting layer positioned therebetween. Electrons injected from a cathode that is an electrode and holes injected from an anode that is another electrode are combined to each other in the organic light emitting layer to form excitons. Light is emitted while the excitons discharge energy.

[0004] As organic light emitting diode (OLED) display technology is developed, organic light emitting diode (OLED) displays are becoming high resolution. Accordingly, there is a growing need for highly integrated organic light emitting diode displays.

SUMMARY

[0005] An organic light emitting diode display according to an exemplary embodiment includes: a substrate; a first buffer layer on the substrate; a first semiconductor layer on the first buffer layer; a first gate insulating layer on the first semiconductor layer; a first gate electrode and a blocking layer on the first gate insulating layer; a second buffer layer on the first gate electrode; a second semiconductor layer on the second buffer layer; a second gate insulating layer on the second semiconductor layer; and a second gate electrode on the second gate insulating layer.

[0006] The blocking layer may overlap the second semiconductor layer.

[0007] The blocking layer may be at the same layer as the first gate electrode.

[0008] The organic light emitting diode display according to the present exemplary embodiment may further include a driving voltage line transmitting a driving voltage, and the blocking layer may be connected to the driving voltage line to receive the driving voltage.

[0009] The first semiconductor layer may include: a first channel region overlapping the first gate electrode; and a first source region and a first drain region at respective sides of the first channel region, and the second semiconductor layer may include: a second channel region overlapping the second gate electrode; and a second source region and a second drain region at respective sides of the second channel region.

[0010] The blocking layer may overlap the second channel region.

[0011] A third gate insulating layer on the second gate electrode, and a second storage electrode on the third gate

insulating layer and overlapping a first storage electrode of the second gate electrode, may be further included.

[0012] A first source electrode and a first drain electrode respectively connected to the first source region and the first drain region, and a second source electrode and a second drain electrode respectively connected to the second source region and the second drain region, may be further included, and the second storage electrode may be connected to the second drain electrode.

[0013] A pixel electrode on the second storage electrode, an organic emission layer on the pixel electrode, and a common electrode on the organic emission layer may be further included, and the second drain electrode may be connected to the pixel electrode.

[0014] An encapsulation layer on the common electrode may be further included.

[0015] A first source electrode and a first drain electrode respectively connected to the first source region and the first drain region, and a second source electrode and a second drain electrode respectively connected to the second source region and the second drain region, may be further included, and the second storage electrode may be connected to the driving voltage line.

[0016] One of the first semiconductor layer and the second semiconductor layer may be an oxide semiconductor and the other may include polysilicon.

[0017] An organic light emitting diode display according to an exemplary embodiment includes: a substrate; a first transistor on the substrate; a second transistor on the first transistor; and a blocking layer under the second transistor, wherein the first transistor includes: a first semiconductor layer on the substrate; and a first gate electrode on the first semiconductor layer, wherein the blocking layer is on a layer overlying the first semiconductor layer.

[0018] A buffer layer between the first transistor and the second transistor may be further included, and the second transistor may include a second semiconductor layer on the buffer layer, and a second gate electrode on the second semiconductor layer.

[0019] The second semiconductor layer may include a channel region overlapping the second gate electrode, and a source region and a drain region at respective sides of the channel region, and the blocking layer may overlap the channel region.

[0020] The organic light emitting diode display according to the present exemplary embodiment may further include a driving voltage line transmitting a driving voltage, and the blocking layer is connected to the driving voltage line to receive the driving voltage.

[0021] The blocking layer may be in the same layer as the first gate electrode.

[0022] The first transistor may include a third gate electrode on the first gate electrode and overlapping the first gate electrode, and the blocking layer may be on the same layer as the third gate electrode.

[0023] The blocking layer may also overlap the source region and the drain region of the second semiconductor layer.

[0024] One of the first semiconductor layer and the second semiconductor layer may be an oxide semiconductor and the other may include polysilicon.

BRIEF DESCRIPTION OF THE DRAWINGS

[0025] Features will become apparent to those of skill in the art by describing in detail exemplary embodiments with reference to the attached drawings in which:

[0026] FIG. 1 illustrates an organic light emitting diode display according to an exemplary embodiment.

[0027] FIG. 2 illustrates an equivalent circuit diagram of one pixel of an organic light emitting diode display according to an exemplary embodiment.

[0028] FIG. 3 illustrates a cross-sectional view of an organic light emitting diode display according to an exemplary embodiment.

[0029] FIG. 4 illustrates a graph showing an instantaneous afterimage duration of an organic light emitting diode display according to a comparative example and an exemplary embodiment.

[0030] FIG. 5 illustrates an equivalent circuit diagram of one pixel of an organic light emitting diode display according to another exemplary embodiment.

[0031] FIG. 6 illustrates a cross-sectional view of an organic light emitting diode display according to another exemplary embodiment.

[0032] FIG. 7 illustrates a cross-sectional view of an organic light emitting diode display according to another exemplary embodiment.

DETAILED DESCRIPTION

[0033] Example embodiments will now be described more fully hereinafter with reference to the accompanying drawings; however, they may be embodied in different forms and should not be construed as limited to the embodiments set forth herein. Rather, these embodiments are provided so that this disclosure will be thorough and complete, and will fully convey exemplary implementations to those skilled in the art.

[0034] In order to clearly explain the embodiments, elements not directly related to thereto are omitted, and the same reference numerals are attached to the same or similar constituent elements through the entire specification.

[0035] In addition, the size and thickness of each configuration shown in the drawings are arbitrarily shown for better understanding and ease of description. In the drawings, the thickness of layers, films, panels, regions, etc., are exaggerated for clarity. In the drawings, for better understanding and ease of description, the thicknesses of some layers and areas are exaggerated.

[0036] It will be understood that when an element such as a layer, film, region, or substrate is referred to as being “on” another element, it can be directly on the other element or intervening elements may also be present. In contrast, when an element is referred to as being “directly on” another element, there are no intervening elements present. Further, in the specification, the word “on” or “above” means positioned on or below the object portion, and does not necessarily mean positioned on the upper side of the object portion based on a gravitational direction.

[0037] In addition, unless explicitly described to the contrary, the word “comprise” and variations such as “comprises” or “comprising” will be understood to imply the inclusion of stated elements but not the exclusion of any other elements.

[0038] Further, in this specification, the phrase “on a plane” means viewing a target portion from the top, and the

phrase “on a cross-section” means viewing a cross-section formed by vertically cutting a target portion from the side.

[0039] FIG. 1 is a block diagram of an organic light emitting diode display according to an exemplary embodiment. Referring to FIG. 1, the organic light emitting diode display according to an exemplary embodiment may include a gate driver GD, a data driver DD, and a pixel unit 40. The pixel unit 40 includes a plurality of pixels PX. The pixel PX means a minimum unit for displaying, and the organic light emitting diode display displays an image through the plurality of pixels PX.

[0040] The gate driver GD generates a scan signal corresponding to driving power and control signals, which are supplied from the outside, and supplies the scan signal to a gate line 152. The pixels PX are selected by the scan signal to sequentially receive a data voltage.

[0041] The gate driver GD may be a thin film transistor on a substrate along with a pixel circuit included in the pixel unit 40 or may be mounted on the substrate in a chip shape, and may be variously positioned around the pixel unit 40.

[0042] The data driver DD generates a data voltage corresponding to data and control signals, which are supplied from the outside, and supplies the data voltage to a data line 171, and may be variously positioned around the pixel unit 40. The data voltage supplied to the data line 171 is supplied to the pixel PX selected by the scan signal whenever the scan signal is supplied. According to an embodiment, the organic light emitting diode display may further include a light emission control driver that supplies a light emission control signal.

[0043] The pixel unit 40 includes a plurality of pixel PXs at the intersection of a gate line 152 and a data line 171. The pixel unit 40 receives a driving voltage ELVDD as a high potential pixel power and a common voltage ELVSS as a low potential pixel power from the outside, and the driving voltage ELVDD and the common voltage ELVSS are transmitted to each pixel PX.

[0044] The pixel PX emits light having a luminance corresponding to a driving current flowing from the driving voltage ELVDD to the common voltage ELVSS corresponding to the data voltage, thereby displaying the image.

[0045] Hereinafter, the organic light emitting diode display according to an exemplary embodiment will be described with reference to FIG. 2 and FIG. 3. FIG. 2 is an equivalent circuit diagram of one pixel of an organic light emitting diode display according to an exemplary embodiment. FIG. 3 illustrates a cross-sectional view of an organic light emitting diode display according to an exemplary embodiment.

[0046] Referring to FIG. 2, the organic light emitting diode display according to an exemplary embodiment includes a plurality of signal lines 152, 171, and 172, a plurality of transistors T1 and T2, a storage capacitor Cst, and an organic light emitting diode OLED. Also, the organic light emitting diode display according to the present exemplary embodiment includes a blocking layer 160 that overlaps the driving transistor T2 on a plane, e.g., along a vertical direction DV orthogonal to the plane, as may be seen in FIG. 3.

[0047] The signal lines 152, 171, and 172 include a gate line 152 transmitting the scan signal Sn, a data line 171 transmitting the data voltage Dm, and a driving voltage line

172 transmitting the driving voltage ELVDD. The transistors **T1** and **T2** include a switching transistor **T1** and a driving transistor **T2**.

[0048] The switching transistor **T1** includes a gate electrode connected to the gate line **152**, a first electrode connected to the data line **171**, and a second electrode connected to a gate electrode of the driving transistor **T2**. The second electrode of the switching transistor **T1** is also connected to a first storage electrode of the storage capacitor **Cst**. The switching transistor **T1** is connected to the gate line **152** to be turned on in response to the scan signal **Sn**, and when the switching transistor **T1** is turned on, the data voltage **Dm** supplied through the data line **171** is supplied to the first storage electrode of the first storage capacitor **Cst**.

[0049] A first electrode of the driving transistor **T2** may be connected to the driving voltage line **172** and to the blocking layer **160**. The gate electrode of the driving transistor **T2** may be connected to the storage capacitor **Cst** such that the first storage electrode receiving the first electrode driving voltage ELVDD. A second electrode of the driving transistor **T2** may be connected to the first electrode of the organic light emitting diode **OLED** and to a second storage electrode of the storage capacitor **Cst**. The driving transistor **T2** outputs the driving current to the organic light emitting diode **OLED** depending on the data voltage stored in the storage capacitor **Cst**.

[0050] The storage capacitor **Cst** includes the first storage electrode and the second storage electrode. The first storage electrode of the storage capacitor **Cst** is connected to the second electrode of the switching transistor **T1** and to the gate electrode of the driving transistor **T2**. The second storage electrode of the storage capacitor **Cst** is connected to the second electrode of the driving transistor **T2** and to the first electrode of the organic light emitting diode **OLED**. The storage capacitor **Cst** may store the data voltage **Dm** supplied through the switching transistor **T1**. The data voltage **Dm** stored to the storage capacitor **Cst** determines a magnitude of the driving current by controlling a turn-on degree of the driving transistor **T2**. While, FIG. 2 shows the structure including two transistors and one capacitor, one or more transistors or capacitors may be additionally included.

[0051] The organic light emitting diode **OLED** includes the first electrode connected to the second electrode of the driving transistor **T2** and a second electrode connected to the common voltage ELVSS. The first electrode of the organic light emitting diode **OLED** may be an anode and the second electrode of the organic light emitting diode **OLED** may be a cathode. The organic light emitting diode **OLED** emits light depending the driving current output from the driving transistor **T2** and displays a gray scale depending on a brightness degree.

[0052] The blocking layer **160** is electrically connected to the driving voltage line **172** that transmits the driving voltage ELVDD. The blocking layer **160** may be formed of a metal having a conductive characteristic or a semiconductor material having a conductive characteristic equivalent thereto. The driving voltage ELVDD is constantly applied to the blocking layer **160** to prevent the potential from being changed while a certain charge is injected into the blocking layer **160**. The blocking layer **160** has a function like the second gate electrode of the driving transistor **T2** in a circuit diagram. However, since the predetermined voltage is

applied to the blocking layer **160**, the driving transistor **T2** is not turned on, but the driving transistor **T2** has a predetermined characteristic.

[0053] Referring to FIG. 3, the organic light emitting diode display according to the present exemplary embodiment includes a substrate **110**, the switching transistor **T1**, the driving transistor **T2**, and the organic light emitting diode **OLED**.

[0054] The substrate **110** may include a flexible material that may be bent, curved, and folded such as plastic. For example, the substrate **110** may be made of a polymer, e.g., polyimide, polyamide, polycarbonate, polyethylene terephthalate, or the like. The substrate **110** may be a rigid substrate made of a material such as glass.

[0055] A first buffer layer **121** is on the substrate **110**. The first buffer layer **121** may include a silicon nitride (SiN_x), a silicon oxide (SiO_x), etc. As the first buffer layer **121** is between the substrate **110** and a first semiconductor layer **136a**, an impurity is prevented from being diffused into the first semiconductor layer **136a** from the substrate **110** and planarizes the substrate **110**, thereby alleviating stress on the first semiconductor layer **136a** formed on the first buffer layer **121**.

[0056] The first semiconductor layer **136a** is on the first buffer layer **121**. The first semiconductor layer **136a** may be made of a polysilicon. For example, the first semiconductor layer **136a** may be made of a polysilicon formed by crystallizing amorphous silicon by a crystallization method such as excimer laser annealing (ELA). The first semiconductor layer **136a** may include a first channel region **134a**, a first source region **133a**, and a first drain region **135a**. The first source region **133a** and the first drain region **135a** are on respective sides of the first channel region **134a**. The first channel region **134a** is an intrinsic semiconductor in which an impurity is not doped, and the first source region **133a** and the first drain region **135** are impurity semiconductors in which a conductive impurity is doped. The conductive impurity may be a P-type impurity.

[0057] A first gate insulating layer **122** is on the first semiconductor layer **136a**. The first gate insulating layer **122** may be a single layer including at least one of a silicon nitride (SiN_x), a silicon oxide (SiO_x), a multilayer thereof, or the like.

[0058] A first gate electrode **155a** and the blocking layer **160** are on, e.g., directly on, the first gate insulating layer **122**. The blocking layer **160** is in the same layer as the first gate electrode **155a**, e.g., directly on the first gate insulating layer **122**, but may be closer to the substrate **110** along the vertical direction **DV** due to the first semiconductor layer **136a** being between the first gate electrode **155a** and the substrate **110**.

[0059] The first gate electrode **155a** may be a multilayer including a metal layer which includes at least one of copper (Cu), a copper alloy, aluminum (Al), an aluminum alloy, molybdenum (Mo), and a molybdenum alloy. The first gate electrode **155a** and the first semiconductor layer **136a** may configure the switching transistor **T1**.

[0060] The blocking layer **160** is formed together in the same layer as the first gate electrode **155a**, e.g., without an additional mask process, thereby simplifying the process. The blocking layer **160** is electrically connected to the driving voltage line **172** through an opening to receive the driving voltage ELVDD. The blocking layer **160** may be

formed of a metal having a conductive characteristic, or a semiconductor material having a conductive characteristic equivalent thereto.

[0061] A second buffer layer 141 is on the first gate electrode 155a, the blocking layer 160, and the first gate insulating layer 122. The second buffer layer 141 may include a silicon nitride (SiN_x), a silicon oxide (SiO_x), etc. The second buffer layer 141 has openings respectively exposing the first source region 133a and the first drain region 135a, as well as the blocking layer 160.

[0062] The second semiconductor layer 136b is on the second buffer layer 141. The second semiconductor layer 136b includes a second channel region 134b, a second source region 133b, and a second drain region 135b. The second source region 133b and the second drain region 135b are on respective sides of the second channel region 134b.

[0063] The second semiconductor layer 136b may be made of an oxide semiconductor. Although the first semiconductor layer 136a is made of the polysilicon and the second semiconductor layer 136b is the oxide semiconductor, the first semiconductor layer 136a of the switching transistor T1 may be formed of the oxide semiconductor having an off current characteristic that is better than that of the polysilicon, and the second semiconductor layer 136b of the driving transistor T2 may be formed of the polysilicon. Alternatively, both the first semiconductor layer 136a and the second semiconductor layer 136b may be made of the same material, e.g., polysilicon or oxide semiconductor.

[0064] A second gate insulating layer 123 is on the second semiconductor layer 136b. The second gate insulating layer 123 may be a single layer including at least one of a silicon nitride (SiN_x), a silicon oxide (SiO_x), the multilayer, or the like.

[0065] A first source electrode 161a and a first drain electrode 162a are on the second gate insulating layer 123. The first source electrode 161a and the first drain electrode 162a are respectively connected to the first source region 133a and the first drain region 135a of the first semiconductor layer 136a through the openings formed in the first gate insulating layer 122, the second buffer layer 141, and the second gate insulating layer 123.

[0066] A second gate electrode 155b overlapping the second channel region 134b is also on the second gate insulating layer 123. The second gate electrode 155b may be a multilayer including a metal layer which includes at least one of copper (Cu), a copper alloy, aluminum (Al), an aluminum alloy, molybdenum (Mo), a molybdenum alloy, or the like. The second gate electrode 155b and the second semiconductor layer 136b may configure the driving transistor T2.

[0067] In the organic light emitting diode display according to the present exemplary embodiment, the switching transistor T1 and the driving transistor T2 are on the different layers. In other words, the first semiconductor layer 136a of the switching transistor T1 and the second semiconductor layer 136b of the driving transistor T2 are on the different layers. Therefore, an interval along a horizontal direction DH between the switching transistor T1 and the driving transistor T2 may be narrowed or these transistors may partially overlap along the vertical direction DV, thereby increasing a degree of design freedom, increasing an aperture ratio of the pixel, and/or increasing the resolution of the display device.

[0068] The blocking layer 160 may overlap the second channel region 134b of the driving transistor T2 along the vertical direction DV. The blocking layer 160 may also overlap the second source region 133b and the second drain region 135b at respective sides of the second channel region 134b, e.g., may overlap an entirety of the second semiconductor layer 136b. Also, the blocking layer 160 may not overlap the first channel region 134a of the switching transistor T1. As the blocking layer 160 is under the driving transistor T2, a kickback voltage due to a parasitic capacitance of the switching transistor T1 and the driving transistor T2 may be minimized, and the display quality of the organic light emitting diode display may be improved by preventing a residual image, as described in detail below. In addition, the blocking layer 160 below the second semiconductor layer 136b is not floated, but receives the driving voltage ELVDD, e.g., may extend beyond the second semiconductor layer 136b along the horizontal direction DH to receive the driving voltage ELVDD, thereby preventing deterioration of the display quality due to the unnecessary parasitic capacitance.

[0069] A third gate insulating layer 124 is on the second gate insulating layer 123, the first source electrode 161a, the first drain electrode 162a, and the second gate electrode 155b. A second drain electrode 162b and a second storage electrode 165 that extends from the second drain electrode 162b along the horizontal direction DH are on the third gate insulating layer 124.

[0070] The second drain electrode 162b is connected to the second drain region 135b of the driving transistor T2 through the opening formed in the second gate insulating layer 123 and the third gate insulating layer 124. The second storage electrode 165 extends from the second drain electrode 162b along the horizontal direction DH to overlap the second gate electrode 155b. The second gate electrode 155b and the second storage electrode 165 overlap each other along the vertical direction DV via the third gate insulating layer 124 to form the storage capacitor Cst. In this case, the second gate electrode 155b may be the first storage electrode of the storage capacitor Cst. The third gate insulating layer 124 is a dielectric material, and the storage capacitance is determined by the charge charged in the storage capacitor Cst and the voltage between the first storage electrode 155b and the second storage electrode 165.

[0071] An interlayer insulating layer 142 is on the third gate insulating layer 124 and the second storage electrode 165. The interlayer insulating layer 142 may be the single layer including at least one of a silicon nitride (SiN_x), a silicon oxide (SiO_x), the multilayer, or the like.

[0072] A second source electrode 161b and a connecting member 174 are on the interlayer insulating layer 142. The second source electrode 161b is connected to the second source region 133b of the second semiconductor layer 136b through the opening in the interlayer insulating layer 142, the second gate insulating layer 123, and the third gate insulating layer 124. The connecting member 174 is connected to the second drain electrode 162b of the driving transistor T2 and the second storage electrode 165 of the storage capacitor Cst through the opening in the interlayer insulating layer 142.

[0073] The second source electrode 161b extends and is connected to the driving voltage line 172 to receive the driving voltage ELVDD. The second source electrode 161b is also connected to the blocking layer 160 through the

opening in the second buffer layer 141, the second gate insulating layer 123, the third gate insulating layer 124, and the interlayer insulating layer 142. Accordingly, the blocking layer 160 is not floated and receives the driving voltage ELVDD.

[0074] The data line 171 is also on the interlayer insulating layer 142. The data line 171 is connected to the first source electrode 161a of the switching transistor T1 through the opening in the third gate insulating layer 124 and the interlayer insulating layer 142 to transmit the data voltage to the switching transistor T1.

[0075] A passivation layer 180 is on the interlayer insulating layer 142, the data line 171, the second source electrode 161b, and the connecting member 174. The passivation layer 180 covers the interlayer insulating layer 142, the second source electrode 161b, the data line 171, and the connecting member 174 to provide a flat upper surface so that a pixel electrode 191 may be formed without a step on the passivation layer 180. The passivation layer 180 may be formed of an organic material, e.g., a polyacrylate resin, a polyimide resin, or the like, or a laminated film of an organic material and an inorganic material.

[0076] The pixel electrode 191 is on the passivation layer 180. The pixel electrode 191 is connected to the connecting member 174 through the opening formed in the passivation layer 180. Accordingly, the pixel electrode 191 is connected to the second drain electrode 162b of the driving transistor T2 through the connecting member 174. The driving transistor T2 is connected to the pixel electrode 191 to supply the driving current to the organic light emitting element.

[0077] A partition wall 361 covers the passivation layer 180 and the pixel electrode 191, and has a pixel opening 365 exposing the pixel electrode 191. The partition wall 361 may include an organic material, e.g., a polyacrylate resin, a polyimide resin, or the like, or an inorganic material, e.g., a silica-based inorganic material.

[0078] An organic emission layer 370 is on the pixel electrode 191 exposed by the pixel opening 365. The organic emission layer 370 may be formed of a low molecular organic material and a high molecular organic material such as or PEDOT (poly(3,4-ethylenedioxythiophene)), etc. Also, the organic emission layer 370 may be a multilayer further including at least one among a hole injection layer (HIL), a hole transporting layer (HTL), an electron transporting layer (ETL), an electron injection layer (EIL), or the like. The organic emission layer 370 may include a red organic emission layer emitting red light, a green organic emission layer emitting green light, and a blue organic emission layer emitting blue light.

[0079] A common electrode 270 is on the organic emission layer 370. The common electrode 270 may cover a plurality of pixels. The pixel electrode 191, the organic emission layer 370, and the common electrode 270 may form the organic light emitting diode OLED.

[0080] Here, the pixel electrode 191 may be the anode of the hole injection electrode, and the common electrode 270 may be the cathode of the electron injection electrode. Alternatively, depending on a driving method of the organic light emitting diode display, the pixel electrode 191 may be the cathode and the common electrode 270 may be the anode. Holes and electrons are respectively injected from the pixel electrode 191 and the common electrode 270 into the organic emission layer 370, and light is emitted when

excitons which are combinations of the injected holes and electrons fall from an excited state to a ground state.

[0081] An encapsulation layer 390 is on the common electrode 270. The thin film encapsulation layer 390 encapsulates the organic light emitting diode OLED, thereby preventing penetration of external moisture and oxygen, as the organic light emitting diode OLED is very vulnerable to the moisture and oxygen. The encapsulation layer 390 may include a plurality of layers, and may be formed of a composite film including both an inorganic film and an organic film. The encapsulation layer 390 may be formed of a triple layer in which an inorganic film, an organic film, and an inorganic film are sequentially formed.

[0082] FIG. 4 is a graph showing an instantaneous afterimage duration of an organic light emitting diode display according to a comparative example and an exemplary embodiment. In FIG. 4, A represents the organic light emitting diode display according to the comparative example without a blocking layer, and B represents the organic light emitting diode display including a blocking layer that overlaps the channel region of the driving transistor according to an exemplary embodiment.

[0083] In the organic light emitting diode display, if black and white are displayed for 10 seconds and then a low gray is simultaneously driven, a difference in luminance occurs in the region displaying black and the region displaying white even though the same colors are driven. In detail, the region displaying black is brighter than the gray to be driven immediately after the gray driving of the low gray, and the region displaying white is darker than the gray to be driven. The instantaneous afterimage means an afterimage recognized by the luminance difference.

[0084] The duration of the instantaneous afterimage of FIG. 4 is found by measuring the time that the difference in luminance between the region displaying black from immediately after the gray driving of the low gray and the region displaying white reaches 0.4%. Here, the luminance difference is calculated by $(B-W)/(B+W)$, where B is the luminance of the region displaying black and W is the luminance of the region displaying white. The instantaneous afterimage is directly related to the display quality of the display device, so that if the duration of the instantaneous afterimage is reduced, a clearer image may be achieved. This instantaneous afterimage may be improved by minimizing vertical cross-talk between the transistors in the organic light emitting diode display.

[0085] Referring to FIG. 4, in the case A, the instantaneous afterimage lasts for 7.66151 seconds. However, in the case B, the instantaneous afterimage lasts for only 4.42379 seconds. Accordingly, an organic light emitting diode display including the blocking layer according to embodiments improves the instantaneous afterimage by about 3.2 seconds compared with the organic light emitting diode display (the comparative example) without the blocking layer.

[0086] Next, the organic light emitting diode display according to an exemplary embodiment will be described with reference to FIG. 5 and FIG. 6. FIG. 5 is an equivalent circuit diagram of one pixel of an organic light emitting diode display according to another exemplary embodiment.

[0087] Referring to FIG. 5, the organic light emitting diode display according to an exemplary embodiment includes signal lines 152, 171, and 172, two transistors T1 and T2, the storage capacitor Cst, and the organic light emitting diode OLED. Also, the organic light emitting diode

display according to the present exemplary embodiment includes the blocking layer 160 that overlaps the driving transistor T2 on a plane, e.g., along the vertical direction DV. Except for the second storage electrode of the storage capacitor Cst, which is connected to the driving voltage line 172 and the first electrode of the driving transistor T2, this embodiment is similar to that of FIG. 2, and redundant description is not repeated.

[0088] The storage capacitor Cst includes the first storage electrode and the second storage electrode. The first storage electrode of the storage capacitor Cst is connected to the second electrode of the switching transistor T1 and the gate electrode of the driving transistor T2. The second storage electrode of the storage capacitor Cst is connected to the driving voltage line 172. The second storage electrode of the storage capacitor Cst is also connected to the first electrode of the driving transistor T2 and the blocking layer 160.

[0089] The storage capacitor Cst may store the data voltage Dm supplied through the switching transistor T1. The data voltage Dm stored in the storage capacitor Cst determines the magnitude of the driving current by adjusting the degree to which the driving transistor T2 turns on.

[0090] The blocking layer 160 is electrically connected to the driving voltage line 172 that transmits the driving voltage ELVDD. The driving voltage ELVDD is constantly applied to the blocking layer 160 to prevent the potential from being changed while a certain charge is injected into the blocking layer 160. The blocking layer 160 has a function like the second gate electrode of the driving transistor T2 in a circuit diagram. However, since the predetermined voltage is applied to the blocking layer 160, the driving transistor T2 is not turned on, but the driving transistor T2 has a predetermined characteristic.

[0091] FIG. 6 is a cross-sectional view of an organic light emitting diode display according to another exemplary embodiment. The configuration of FIG. 6 is similar to that of FIG. 3 such that the detailed description overlapping with FIG. 3 is not repeated.

[0092] Referring to FIG. 6, the organic light emitting diode display according to the present exemplary embodiment includes the substrate 110, the switching transistor T1, the driving transistor T2, and the organic light emitting diode OLED.

[0093] The second source electrode 161b extends and is connected to the driving voltage line 172 to receive the driving voltage ELVDD. The second source electrode 161b is also connected to the blocking layer 160 through the opening in the second buffer layer 141, the second gate insulating layer 123, the third gate insulating layer 124, and the interlayer insulating layer 142. Accordingly, the blocking layer 160 is not floated and receives the driving voltage ELVDD.

[0094] Additionally, different from FIG. 3, the second source electrode 161b is also connected to the second storage electrode 165 of the storage capacitor Cst through the opening formed in the interlayer insulating layer 142, and the second storage electrode 165 is not connected to the second drain electrode 162b. Accordingly, the second storage electrode 165 of the storage capacitor Cst receives the driving voltage ELVDD. Otherwise, the remainder of the structure is the same as in FIG. 3.

[0095] FIG. 7 is a cross-sectional view of an organic light emitting diode display according to another exemplary embodiment. Referring to FIG. 7, the organic light emitting

diode display according to the present exemplary embodiment includes the first transistor T1, the second transistor T2, and a blocking layer 260.

[0096] The organic light emitting diode display according to the present exemplary embodiment includes a substrate 210 and a first buffer layer 221 on the substrate 210.

[0097] A first semiconductor layer 236a is on the first buffer layer 221. The first semiconductor layer 236a may be made of polysilicon, and includes a first channel region 234a, a first source region 233a, and a first drain region 235a. The first source region 233a and the first drain region 235a are at respective sides of the first channel region 234a.

[0098] A first gate insulating layer 222 is on the first semiconductor layer 236a and a first gate electrode 255a is on the first gate insulating layer 222. The first gate electrode 255a overlaps the first channel region 234a of the first semiconductor layer 236a. The first gate electrode 255a and the first semiconductor layer 236a may form the first transistor T1.

[0099] A second gate insulating layer 223 is on the first gate electrode 255a. A second gate electrode 265 and the blocking layer 260 are on the second gate insulating layer 223. The second gate electrode 265 overlaps the first gate electrode 255a and the first channel region 234a of the first semiconductor layer 236a along the vertical direction DV. Along the vertical direction DV, the first gate electrode 255a and the second gate electrode 265 overlap and are spaced apart by the second gate insulating layer 223, thereby forming the storage capacitor.

[0100] The blocking layer 260 is in the same layer, e.g., directly on the second gate insulating layer 223, as the second gate electrode 265, but may be closer to the substrate 210 along the vertical direction DV due to the first semiconductor layer 236a being between the second gate electrode 265 and the substrate 210. The blocking layer 260 is electrically connected to a driving voltage line 272 through the opening to receive the driving voltage ELVDD. The blocking layer 260 may be formed of the metal having the conductive characteristic or the semiconductor material having the conductive characteristic equivalent thereto.

[0101] A second buffer layer 241 is on the second gate electrode 265, the blocking layer 260, and the second gate insulating layer 223. A second semiconductor layer 236b is on the second buffer layer 241. The second semiconductor layer 236b includes a second channel region 234b, a second source region 233b, and a second drain region 235b. The second source region 233b and the second drain region 235b are at respective sides of the second channel region 234b. The second semiconductor layer 236b may be made of the oxide semiconductor.

[0102] A third gate insulating layer 224 is on the second semiconductor layer 236b. A third gate electrode 255b overlapping the second channel region 234b is on the third gate insulating layer 224. The third gate electrode 255b and the second semiconductor layer 236b may form the second transistor T2.

[0103] The blocking layer 260 overlaps the second channel region 234b of the second transistor T2. The blocking layer 260 may also overlap the second source region 233b and the second drain region 235b at respective sides of the second channel region 234b, e.g., may overlap an entirety of the second semiconductor layer 236b. Also, the blocking layer 260 may not overlap the first channel region 234a of the first transistor T1.

[0104] It is described that the first semiconductor layer 236a of the first transistor T1 is made of the polysilicon and the second semiconductor layer 236b of the second transistor T2 is made of the oxide semiconductor, but it is possible for the first semiconductor layer 236a to be made of the oxide semiconductor and the second semiconductor layer 236b to be made of the polysilicon. Alternatively, both the first semiconductor layer 236a and the second semiconductor layer 236b may be made of the same material, e.g., polysilicon or oxide semiconductor.

[0105] An interlayer insulating layer 242 is on the third gate electrode 255b and the third gate insulating layer 224. A first source electrode 261a, a first drain electrode 262a, a second source electrode 261b, a second drain electrode 262b, and the driving voltage line 272 are on the interlayer insulating layer 242.

[0106] The first source electrode 261a and the first drain electrode 262a are respectively connected to the first source region 233a and the first drain region 235a of the first semiconductor layer 236a through the openings in the second buffer layer 241, first to third gate insulating layers 222 to 224, and the interlayer insulating layer 242.

[0107] Further, the second source electrode 261b and the second drain electrode 262b are respectively connected to the second source region 233b and the second drain region 235b of the second semiconductor layer 236b through the openings in the interlayer insulating layer 242 and the third gate insulating layer 224.

[0108] Finally, the driving voltage line 272 is connected to the blocking layer 260 through the opening in the second buffer layer 241, the interlayer insulating layer 242, and the third gate insulating layer 224.

[0109] By way of summation and review, embodiments herein may provide an organic light emitting diode display having increased design freedom, high resolution, and improved display quality.

[0110] Example embodiments have been disclosed herein, and although specific terms are employed, they are used and are to be interpreted in a generic and descriptive sense only and not for purpose of limitation. In some instances, as would be apparent to one of ordinary skill in the art as of the filing of the present application, features, characteristics, and/or elements described in connection with a particular embodiment may be used singly or in combination with features, characteristics, and/or elements described in connection with other embodiments unless otherwise specifically indicated. Accordingly, it will be understood by those of skill in the art that various changes in form and details may be made without departing from the spirit and scope of the present invention as set forth in the following claims.

What is claimed is:

1. An organic light emitting diode display, comprising:
 - a substrate;
 - a first buffer layer on the substrate;
 - a first semiconductor layer on the first buffer layer;
 - a first gate insulating layer on the first semiconductor layer;
 - a first gate electrode and a blocking layer on the first gate insulating layer;
 - a second buffer layer on the first gate electrode;
 - a second semiconductor layer on the second buffer layer;
 - a second gate insulating layer on the second semiconductor layer;

a second gate electrode on the second gate insulating layer.

2. The organic light emitting diode display as claimed in claim 1, wherein the blocking layer overlaps the second semiconductor layer.

3. The organic light emitting diode display as claimed in claim 2, wherein the blocking layer is on the same layer as the first gate electrode.

4. The organic light emitting diode display as claimed in claim 3, further comprising:

a driving voltage line transmitting a driving voltage, wherein the blocking layer is connected to the driving voltage line to receive the driving voltage.

5. The organic light emitting diode display as claimed in claim 4, wherein

the first semiconductor layer includes:

a first channel region overlapping the first gate electrode; and

a first source region and a first drain region at respective sides of the first channel region, and

the second semiconductor layer includes:

a second channel region overlapping the second gate electrode; and

a second source region and a second drain region at respective sides of the second channel region.

6. The organic light emitting diode display as claimed in claim 5, wherein the blocking layer overlaps the second channel region.

7. The organic light emitting diode display as claimed in claim 6, further comprising:

a third gate insulating layer on the second gate electrode; and

a second storage electrode on the third gate insulating layer and overlapping a first storage electrode of the second gate electrode.

8. The organic light emitting diode display as claimed in claim 7, further comprising:

a first source electrode and a first drain electrode respectively connected to the first source region and the first drain region; and

a second source electrode and a second drain electrode respectively connected to the second source region and the second drain region, wherein the second storage electrode is connected to the second drain electrode.

9. The organic light emitting diode display as claimed in claim 8, further comprising:

a pixel electrode on the second storage electrode;

an organic emission layer on the pixel electrode; and

a common electrode on the organic emission layer, wherein the second drain electrode is connected to the pixel electrode.

10. The organic light emitting diode display as claimed in claim 9, further comprising an encapsulation layer on the common electrode.

11. The organic light emitting diode display as claimed in claim 7, further comprising:

a first source electrode and a first drain electrode respectively connected to the first source region and the first drain region; and

a second source electrode and a second drain electrode respectively connected to the second source region and the second drain region, wherein the second storage electrode is connected to the driving voltage line.

12. The organic light emitting diode display as claimed in claim **11**, wherein one of the first semiconductor layer and the second semiconductor layer is an oxide semiconductor and the other includes polysilicon.

13. An organic light emitting diode display, comprising:
a substrate;
a first transistor on the substrate;
a second transistor on the first transistor; and
a blocking layer under the second transistor,
wherein the first transistor includes:

a first semiconductor layer on the substrate; and
a first gate electrode on the first semiconductor layer,
wherein the blocking layer is on a layer overlying the first semiconductor layer.

14. The organic light emitting diode display as claimed in claim **13**, further comprising:

a buffer layer between the first transistor and the second transistor,

wherein the second transistor includes:

a second semiconductor layer on the buffer layer; and
a second gate electrode on the second semiconductor layer.

15. The organic light emitting diode display as claimed in claim **14**, wherein the second semiconductor layer includes:
a channel region overlapping the second gate electrode;
and

a source region and a drain region at respective sides of the channel region, wherein the blocking layer overlaps the channel region.

16. The organic light emitting diode display as claimed in claim **15**, further comprising a driving voltage line transmitting a driving voltage, wherein the blocking layer is connected to the driving voltage line to receive the driving voltage.

17. The organic light emitting diode display as claimed in claim **16**, wherein the blocking layer is on the same layer as the first gate electrode.

18. The organic light emitting diode display as claimed in claim **16**, wherein:

the first transistor includes a third gate electrode on the first gate electrode and overlapping the first gate electrode, and

the blocking layer is on the same layer as the third gate electrode.

19. The organic light emitting diode display as claimed in claim **18**, wherein the blocking layer overlaps the source region and the drain region of the second semiconductor layer.

20. The organic light emitting diode display as claimed in claim **19**, wherein one of the first semiconductor layer and the second semiconductor layer is an oxide semiconductor and another includes polysilicon.

* * * * *

专利名称(译)	有机发光二极管显示器		
公开(公告)号	US20200111855A1	公开(公告)日	2020-04-09
申请号	US16/591966	申请日	2019-10-03
[标]申请(专利权)人(译)	三星显示有限公司		
申请(专利权)人(译)	三星DISPLAY CO. , LTD.		
当前申请(专利权)人(译)	三星DISPLAY CO. , LTD.		
[标]发明人	BAE JOON WOO KOO SO YOUNG KIM HAN BIT NGUYEN THANH TIEN LEE KYOUNG WON LEE YONG SU LEE JAE SEOB JO GYOO CHUL		
发明人	BAE, JOON WOO KOO, SO YOUNG KIM, HAN BIT NGUYEN, THANH TIEN LEE, KYOUNG WON LEE, YONG SU LEE, JAE SEOB JO, GYOO CHUL		
IPC分类号	H01L27/32 H01L51/52		
CPC分类号	H01L27/3276 H01L51/5253 H01L27/1225 H01L27/3272 H01L27/1255 H01L27/3262 H01L29/7869 H01L29/78675 H01L29/78633 H01L27/3265 H01L27/124 H01L27/1229 H01L27/3258 H01L29/78648		
优先权	1020180118769 2018-10-05 KR		
外部链接	Espacenet USPTO		

摘要(译)

根据示例性实施例的有机发光二极管显示器包括：基板；基板上的第一缓冲层；在第一缓冲层上的第一半导体层；在第一半导体层上的第一栅极绝缘层；第一栅电极和位于第一栅极绝缘层上的阻挡层；在第一栅电极上的第二缓冲层；在第二缓冲层上的第二半导体层；在第二半导体层上的第二栅极绝缘层；第二栅极绝缘层上的第二栅电极。

